

## Dual-Core or Quad-Core Intel® Xeon® Processor Single Board Computer



### APPLICATIONS

The PP 66x/07x is a PC-compatible very high performance, high functionality, CompactPCI® board supporting either the Dual-Core or Quad-Core Intel® Xeon® processor, utilizing 45nm process technology, and the Intel® 5520 chipset. The processor contains four or two CPU cores and 8 Mbytes shared last level cache. The PP 66x/07x will operate in a left or right system slot, a peripheral slot or independently from the CompactPCI bus. High-performance networking is



provided by three Gigabit Ethernet links, and the board is compliant to PICMG® 2.16. An optional dual 10 Gigabit Ethernet module is also available for high-speed interconnects. Full system monitoring is provided by the PICMG 2.9 compliant IPMI interface. Many industry standard operating systems are supported. The PP 66x/07x is suitable for a range of high-performance applications within the telecomms, security, telemetry, scientific and aerospace markets.

### HIGHLIGHTS

- 2.13 GHz Quad-Core Intel® Xeon® processor L5518 or 2.0 GHz Dual-Core Intel® Xeon® processor L5508:
  - 45nm process technology
  - two execution threads per core
  - 1066 MHz Memory Bus
  - Intel® QuickPath Interconnect (Intel® QPI)
  - 8 Mbytes last level cache shared between cores
  - Intel® 64 architecture (64-bit computing)
  - no CPU fan needed; low power processor
- Up to 64 Gbytes of DDR3-1066 ECC SDRAM
- PMC/XMC module site with front panel I/O:
  - PMC site 64-bit; 133MHz PCI-X
  - XMC interface (up to x8 PCI Express™)
- Optional 8 port SAS/SATA300 hardware RAID controller
- 6 x SATA300 interfaces:
  - 4 interfaces via rear
  - optional on-board disk drive
  - SATA to EIDE interface for on-board CompactFlash™
- 3 x 10/100/1000Mbps Ethernet interfaces:
  - Dual Gigabit Packet Switching Backplane (PICMG 2.16)
- Optional dual 10 Gigabit Ethernet module
- Graphics, keyboard and mouse interfaces on front panel
- 5 x Universal Serial Bus (USB 2.0) interfaces
- 2 x RS232 serial channel interfaces
- CompactPCI controller:
  - operates in left or right system controller slot
  - operates in peripheral slot
  - 32/64-bit at 33/66 MHz CompactPCI interface
- Option to bypass CompactPCI bus (Satellite Mode)
- IPMI (Intelligent Platform Management Interface):
  - PICMG 2.9 (System Management Specification)
- Watchdog timer and Long Duration Timer
- Support for Linux®, Windows® XP, Windows® XP Embedded, Windows® Server 2003, Windows® Server 2008, QNX®, VxWorks® and Solaris™
- Dual slot CompactPCI board
- Optional dual slot Rear Transition Module available:
  - provides all SAS/SATA connectors
  - option for USB Flash disk
  - option for up to two 2.5" SATA300 disk drives

## Central Processor

- 2.13 GHz Quad-Core Intel® Xeon® processor L5518 or 2.0 GHz Dual-Core Intel® Xeon® processor L5508:-
  - 45nm process technology
  - uses 1366-land FCLGA (Flip Chip Land Grid Array) package
  - 1066 MHz Memory Bus
  - Intel® QuickPath Interconnect (Intel® QPI) at 20 Gbytes/sec
  - 8 Mbytes of shared last level on-die cache
  - Intel® 64 architecture (64-bit computing)
- no CPU fan
- utilizes Intel® 5520 chipset:-
  - uses Intel® I/O Controller Hub 10R (Intel® ICH10R)
- provision for XDP debug port

## SDRAM

- up to 64 Gbytes DDR3-1066 ECC SDRAM:-
  - up to 64 Gbytes via four DIMM sockets
  - maximum 32 Gbytes using VLP DIMMs
  - peak bandwidth of 17 Gbytes/s
  - single device data correction support
- accessible from processor and CompactPCI bus

## SAS/SATA RAID interface

- 8 port SAS/SATA300 hardware RAID controller implemented by LSI SAS1068E via a x8 PCI Express™ Link
- 8 x SAS/SATA interfaces:-
  - accessed via J3
  - two Mini SAS 4x connectors (SFF-8088) on the AD PP7/001 Rear Transition Module
- hardware RAID modes supported:-
  - mirror
  - enhanced mirroring
  - striping
- the RAID controller is an optional feature

## Mass Storage Interfaces

- 6 port SATA300 controller implemented by Intel ICH10R
- 4 SATA interfaces via J3:-
  - support for software RAID control
  - 4 x drive connectors available on the AD PP7/001 Rear Transition Module (RTM)
  - option to support up to two on-board 2.5" SATA300 drives on the RTM
- option to fit 1 x SATA for an on-board 2.5" SATA300 drive (uses the PMC/XMC site)
- 1 x SATA port (via EIDE) used for on-board CompactFlash™ site under PMC/XMC site
- option for USB Flash disk module on the RTM

## 10 Gigabit Ethernet Interfaces

- optional module supporting dual 10 Gigabit Ethernet interfaces implemented by an Intel® 82599 10 Gigabit Ethernet Controller via x8 PCI Express link (option not shown on photograph)
- front panel access via SFP+ connectors:-
  - optical fiber SFP+ module or
  - copper SFP+ cable (cable length 20m max)

## Gigabit Ethernet Interfaces

- 2 x rear interfaces implemented by two Intel® 82574L Gigabit Ethernet Controllers via x1 PCI Express™ links:-
  - optional support for PICMG® 2.16 R1.0 - Packet Switching Backplane (PSB)
- front panel RJ45 interface implemented by Intel® 82567 Gigabit Ethernet Controller
- supports 10 Base-T, 100 Base-TX, 1000 Base-T

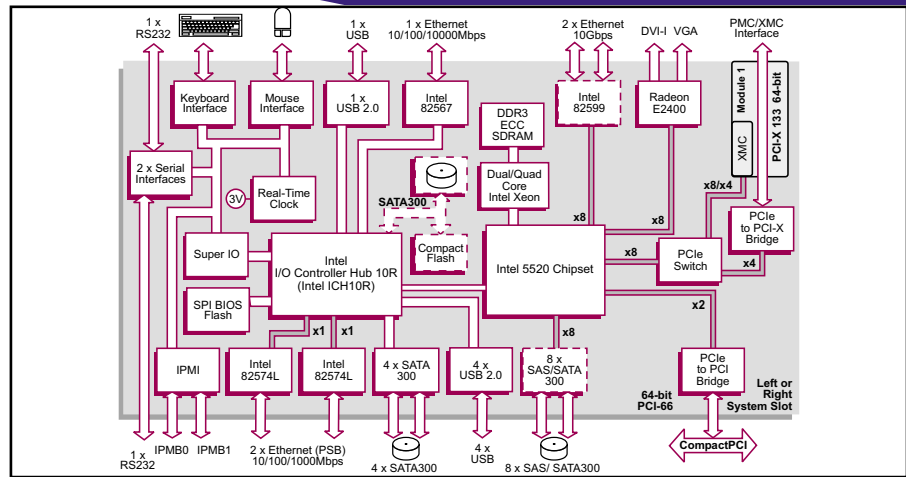

## Graphics Interfaces

- implemented by Radeon E2400 graphics controller via x8 PCI Express Link
- dual independent analog displays
- DVI-I and VGA connectors via front panel:-
  - digital, up to 1920 x 1200 @ 16M colors
  - analog, up to 2048 x 1536 @ 16M colors

## PMC/XMC Interface

- 1 x PMC site which supports:-
  - 32/64-bit, 33/66/100/133 MHz PCI/PCI-X
  - 3.3V or 5V PCI signaling
  - x4 PCI Express to PCI-X bridge
  - I/O via front panel
- XMC PCI Express link supports up to x8:-
  - x4 if PMC PCI/PCI-X- bus enabled
  - dual x4 mode if PCI/PCI-X- bus site disabled

## Serial Interfaces

- 2 x RS232 serial channels:-
  - 1 x Tx/Rx channel accessed via 9-way D connector on front panel
  - 1 x Tx/Rx channel via J3
- 16550 compatible UARTs
- front and rear panel interface support RI, CTS, RTS, DSR, DTR and DCD

## Other Peripheral Interfaces

- PC Real Time Clock (Year 2000 compliant)
- watchdog timer; 32-bit Long Duration Timer with processor interrupt; chipset timer
- system fan monitor; CPU temperature monitor; voltages monitor; all accessible via IPMI
- 5 x USB 2.0 interfaces:-
  - 1 accessed via the front panel
  - 4 interfaces accessed via J3
- independent legacy speaker output via J3
- keyboard and mouse interfaces via front panel

## Flash EPROM

- 4 Mbytes of BIOS Flash EPROM

## Firmware Support

- Insyde Software InsydeH20™ BIOS:-
  - includes Compatibility Support Module
- based upon Intel® Platform Innovation Framework for EFI
- LAN boot firmware included

## Software Support

- support for Linux®, Windows® XP, Windows® XP Embedded, Windows® Server 2003, Windows Server 2008, QNX®, VxWorks® and Solaris™

## IPMI

- PICMG 2.9 R1.0 (System Management Spec.):-
  - implements the IPMB0 and IPMB1 interfaces
- on-board Baseboard Management Controller
- supports 8 Kbytes of non-volatile memory

## CompactPCI Interface

- compliant with PICMG 2.0 R3.0; 3.3V or 5V signaling levels (universal signaling support)
- 33/66 MHz, 32/64-bit interface accessed via J1/J2 connectors
- PCI Express to PCI bridge (off-board accesses)
- PICMG 2.1 R2.0 Hot Swap compliant as a system slot controller
- operates in left or right system controller slot
- operates in peripheral slots
- option to disable CompactPCI interface (Satellite Mode):-
  - receives power from CompactPCI bus
  - board cannot be hot swapped

## Electrical Specification

- +5V@tbd A (typical for Quad-Core 2.13 GHz with 16 Gbytes DRAM); +5% / -3%
- +3.3V@tbd A; +5% / -3%
- +12V@tbd A; -12V@tbd A
- +12V and -12V routed to PMC/XMC site

## Safety

- PCB (PWB) manufactured with flammability rating of 94V-0

## Environmental Specification

- operating temperature:-
  - 0°C to +55°C (N-Series)
- 5% to 95% Relative Humidity, non-condensing (operating and storage)
- 40°C to +85°C (storage)

## Mechanical Specification

- 6U form-factor: 9.2inches x 6.3inches (233mm x 160mm)
- dual-slot: 1.6inches (40.6mm)
- connectors: IEC-1076-4-101 for J1-J5

## ORDERING INFORMATION

Order Number Product Description (Hardware)

PP 660/071-xy 2.0 GHz Dual-Core Intel® Xeon® processor L5508  
 PP 662/071-xy 2.13 GHz Quad-Core Intel® Xeon® processor L5518

AD EX1/002-10 Dual 10 Gigabit Ethernet interfaces via two SFP+ connectors  
 AD PP7/001-zz Dual slot Rear Transition Module

All companies and product names are trademarks of their respective organizations.  
 Specification subject to change; E and OE. RoHS 2002/95/EC compliant.

Replace the order number suffix (xy) with selections from the following:  
 where x = 1 - Ethernet via rear panel, including 8 port RAID  
 2 - Ethernet via PICMG 2.16, including 8 port RAID  
 3 - Ethernet via rear panel, excluding 8 port RAID  
 4 - Ethernet via PICMG 2.16, excluding 8 port RAID  
 where y = memory size  
 y - up to 64 Gbytes

For zz options please contact your local sales office.