



## Powered Rugged ATR Enclosures

For Convection, Conduction and Liquid Cooled Electronic Hardware

System  
Platforms

Backplanes

Enclosures &  
Components

Cabinets

Rotary  
Switches

**ELMA**  
Your Solution Partner

Elma is a global manufacturer of products for housing electronic systems. The company provides everything from components such as modular enclosures, cabinets and backplanes up to complete standard or custom system platforms. Elma also manufactures precision rotary switches. The company offers fast, flexible response to customer needs and extensive practical knowledge in tailoring solutions to specific applications.



SWITZERLAND



USA



GERMANY



UK



FRANCE



ISRAEL



CHINA



ROMANIA

Founded in 1960, Elma is an industry innovator in the design and manufacture of electronic enclosures and passive electronic components. With vast expertise in Eurocard-based platforms, standard architectures include AdvancedTCA, CompactPCI, MicroTCA, Rugged COTS/ATR, VME, VME64x, VPX, VXI, VXS and more. The company also tailors customised solutions to individual applications ensuring fast and cost-effective results.

As a global company, Elma has production and assembly facilities in 8 countries and has representatives in over 40 countries. Elma has a broad base of customers in diverse industries such as telecommunications, industrial control, medical electronics, defence and aerospace.

We provide products superior in quality, reliability, performance, and consistently present new, innovative designs to the market. Elma also offers design and integration services backed by responsive and knowledgeable technical support.

Our leading quality level is reached through training of all employees and following of systematic procedures per ISO 9001 standards to which Elma has been registered.

## Why choose Elma?

- Flexibility** Elma tailors solutions to individual applications to ensure fast and cost-effective results
- Experience** Extensive practical experience in packaging electronic systems is used to minimise the time taken to develop new customised solutions without compromising system performance or reliability.
- Compatibility** Because the two key electromechanical components - enclosure and backplanes - are made in-house, Elma guarantees compatibility, consistency and reliability.
- Global Resources** With manufacturing in Europe, Asia and the USA, customers benefit from local service backed by global resources.

## Custom Solutions

Customisation is standard at Elma. With an extensive offering of modular standard products as a foundation, we are able to leverage existing solutions and proven design concepts to meet any custom application. This approach ensures that Elma will provide quality, compliant solutions with significantly reduced lead time, cost and risk. Combined with our integration capability for both embedded systems and switches we provide a single solution to your outsourcing needs.

## Design Capabilities

Elma has been a leader in design innovation for over 45 years. We use advanced design software and equipment to perfect your design. We can utilise our vast resource of experienced designers and engineers from facilities all over the world. The result is a superb design solution, completed to your specifications in a timely and cost-efficient manner.

## Production Capabilities

From base components to fully integrated computing systems, Elma can be your solution partner each step of the way. With production and assembly facilities worldwide, we can meet nearly any need - whether prototypes or high volumes, quick turn deliveries or highly complex designs.

## CUSTOM SYSTEM PLATFORMS

- Over 20 years of expertise in system design with emphasis on thermal management
- Specialists in EMC, shock/vibration, system monitoring, reliability and maintainability
- Applications for industrial and rugged environments

## CUSTOM BACKPLANES

- Modified standards for all PICMG and VITA specifications
- NSC (non standard-based custom) design
- Proven, reliable high-speed designs with data rates up to 10 Gbps per differential pair

## CUSTOM ENCLOSURES & COMPONENTS

- Modified standards for IEC, IEEE, ATCA,  $\mu$ TCA mechanics or proprietary solutions
- IP protection classes
- EMC compliance

## CUSTOM CABINETS

- Industrial, Rugged, Datacom/Server, or Shielded
- Highly complex or unusual configurations in any volume
- Silk screening, painting, tool making, validation testing, and agency certification

## CUSTOM SWITCHES, KNOBS & LEDs

- Modifiable switches and LEDs
- Integration of switches, panels and other components
- Custom switch bracket fabrication



## ATR SYSTEM ENCLOSURES

Elma's extensive family of ATR system enclosures can be easily adapted to suit most types of support and mounting structure.

Solutions exist to enable the safe, reliable and cost effective deployment of commercial, industrial or military-grade convection cooled hardware in airborne, naval or land mobile (vetronics) applications. Additionally, full military-grade conduction cooled requirements can also be accommodated with Elma's extended and versatile family of conduction cooled ATR enclosures.

This comprehensive and unequalled range of ATR enclosures has evolved as a direct result of the company's widely acknowledged pro-active COTS stance, coupled with extensive applications experience gained through involvement in major international air, sea and land defence projects.

The Elma series of ATRs conforms to ARINC specifications and offers outstanding quality and versatility for many systems architectures from VME to VPX.

These enclosures are available in various case sizes from 1/4 ATR to 1 1/2 ATR and are suitable for horizontal or vertical/top board load applications. Custom sizes and mounting options are also available. A flexible building block approach enables a comprehensive array of application specific options to be incorporated. Completely assembled, harnessed and configured to customer requirements these enclosures form ideal rugged system packaging solutions for immediate deployment in development or target environments.

### GENERAL CONSTRUCTION AND FEATURES

Generally, all direct and some indirect cooled ATR enclosures are fabricated from 2mm or 3mm sheet aluminium with locking bushes or thread lock compound being used throughout to ensure fixing integrity. Internal to the enclosure is a rugged hard-mounted cardframe that can be shock and vibration isolated if required. Constructed from high tensile strength extrusions with screwed-down one-piece aluminium card guides, the cardframe is configurable for either top or side board loading.

The latest EMC design principles and practices are employed guaranteeing inherently good EMC performance. All panel interfaces are fully gasketed for optimum EMC and hermetic performance.



## FEATURES AND BENEFITS

- Comprehensive range of standard/custom ARINC sizes
- Tried and tested deployment history
- Elma's military pedigree backplane options
- Facility for shuttled drives and / or embedded devices
- High altitude fan capabilities
- Top or side board loading
- Withstand the most severe and hostile environments
- Elma's versatile and patented 'High Integrity Frame' design
- Semi- or full- customisation

## OPTIONS

- Full hardware and software integration
- Special support / mounting structures
- Bespoke colour scheming and silk screen printing
- Shuttled power supplies, drives and fans for quick MTTR
- Drive provisions - hard-mounted or shock / vibration isolated
- Full I/O interconnection schemes and integration
- EMC viewing window
- Hot Swap SCSI devices
- Enclosure heaters
- Redundant power supplies
- Alarm generation for fan-fail and climatic monitoring
- Isolation and anti-vibration trays

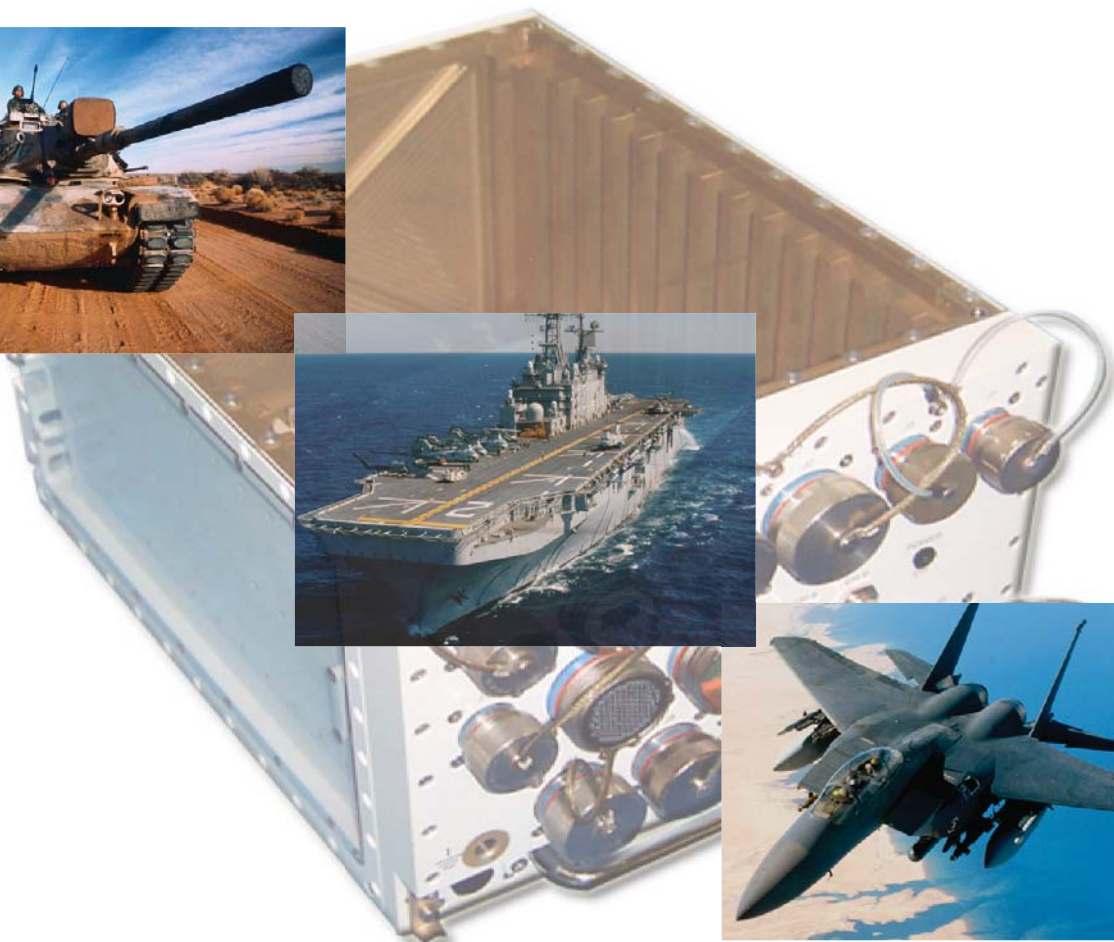

# DIRECT FORCED-AIR COOLED ATR ENCLOSURES

*For safe and reliable deployment of electronic hardware in moisture free air conditions*

Elma's direct forced-air cooled ATR enclosures have been developed to enable the safe, reliable and cost effective deployment of electronic hardware in moisture free air conditions. These enclosures, the first of their kind, were developed specifically for deployment in very harsh environments and have been used in many land, sea and air applications.

## DIRECT FORCED-AIR COOLING



This is the most commonly used form of forced-air cooling, whereby ambient air is forced by the use of fans over the heat dissipating electronic hardware. Ideally suited for the thermal management and effective deployment of convection cooled commercial, industrial or military-grade hardware, providing that the ambient air is not laden with unfriendly or harmful contaminants such as moisture and salt fog. High altitude fan options are available for operation at greater than 10,000 feet.

Direct forced-air cooled ATRs can accommodate a number of thermal management options, including airl evacuation, pressurised forced air, or a combination of both to give a 'push-pull' arrangement. The range can also be specially adapted for externally generated ducted forced-air via avionics mounting tray / plenum assembly. These ATRs are fitted with honeycomb EMI filters and provision can be made for air filtration if required.



## FEATURES AND BENEFITS

- Can be designed to meet most MIL / DEF.STAN specifications
- 2mm / 3mm aluminium construction with locking bushes
- Incorporates Elma's patented 'Crush-Fold' technology
- Honeycomb EMI air inlet / exhaust filters
- Cardframe inset options
- Cabling to DEF.STAN 61-12 Part 18 (limited toxicity)
- Designed for commercial, industrial and military-grade hardware
- Hard-mounted or shock/vibration isolated rugged cardframe
- In accordance with ARINC 404/600
- Evacuation, pressurised or ducted external forced-air cooling



# INDIRECT FORCED-AIR COOLED ATR ENCLOSURES

*For safe and reliable deployment of electronic hardware in moisture laden air conditions*

Elma's indirect forced-air cooled ATR enclosures have been developed to enable safe, reliable and cost effective deployment of electronic hardware in moisture laden air conditions and are particularly suitable for the thermal management of convection cooled commercial, industrial or military-grade hardware. Ambient air is isolated from the air circulating inside the unit and the heat dissipated within is pumped out via an active or passive air-to-air heat exchanger.

## INDIRECT FORCED-AIR COOLING



A technique pioneered by Elma for ATR use, whereby the ambient air is isolated from the air circulating inside the enclosure. The heat dissipated within the enclosure is pumped out via an active or passive air-to-air heat exchanger. Suitable for the thermal management of commercial, industrial or military-grade convection cooled hardware in environments containing moisture laden or contaminated ambient air, as well as sand and dust environments.

## FEATURES AND BENEFITS

- Protects internal electronic hardware from ambient atmosphere
- Incorporates Elma's ATR 'Heat Exchanger' and 'Crush-Fold' technology
- VME, VME64 Exts, VXS, VPX, CompactPCI and proprietary buses
- 2mm / 3mm aluminium construction with locking bushes
- Comprehensive range of power supply options
- In accordance with ARINC 404/600
- Hard-mounted or shock/vibration isolated rugged cardframe

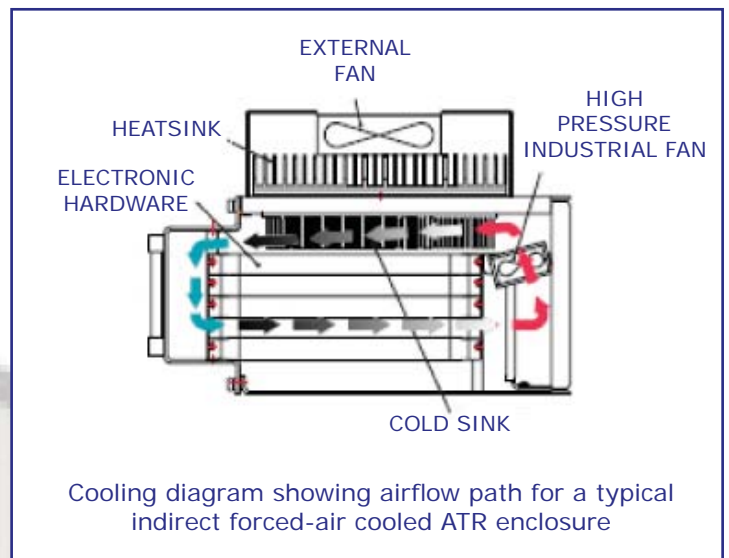

## CONDUCTION COOLED ATR ENCLOSURES

*For safe and reliable deployment of electronic hardware in hostile environments*

Conduction cooled ATR enclosures from Elma are a non-compromise solution for harsh military use and providing the highest level of environmental protection for electronic hardware that exceeds the requirements of MIL-STD-810 and MIL-HDBK-5400. This family of enclosures has evolved as a direct result of the company's involvement in numerous major defence programmes where equipment is required to operate in extremely hostile and demanding environments, particularly in fixed and rotary wing aircraft and land mobile vehicles.

### CONDUCTION COOLING



These enclosures are frequently used for very onerous military applications. The heat generated within the enclosure is strategically conducted through to the outer surfaces and ambient air is then used to cool these surfaces. Certain applications may necessitate an external fan to move the ambient air over the enclosure's outer surfaces. Generally these enclosures are sealed against water and dust and contain breather valves to avoid pressure differences.

This family of conduction cooled ATR enclosures is manufactured from precision-machined aluminium and incorporate a versatile and patented 'High Integrity Frame' construction technique; a revolutionary new approach offering scalability, significant weight savings, excellent thermal efficiency, inherently high levels of manufacturing flexibility combined with significant cost benefits and reduced lead times.

### FEATURES AND BENEFITS

- Designed for conduction cooled CPCI VME, VXS, VPX and custom boards
- Lightweight construction
- AC single / three-phase or DC input
- I/O breakout system for simplified wiring
- Customised backplanes
- Flexi-circuit I/O scheme
- In accordance with ARINC 404/600
- Mil-spec custom PSU solutions



## *For deployment in hostile environments*

The liquid cooled ATR, rated in excess of 1KW (dependant on coolant used), incorporates a dual wall modular design. This is a sophisticated sub-assembly that significantly reduces MTTR; the cooling sidewalls are Line Replacement Units, so swap-out is a very simple process that can be carried out in the field. Each side plate has its own feed and return, making them independent of one another, cooling is still provided in the event of damage to one side; the design also avoids running pipework across the rear face of the chassis, the area most likely to be damaged if the unit is accidentally dropped.

## LIQUID COOLING



The latest development in Elma's ATR family is the liquid cooled version, developed from the company's field-proven air-cooled design that is already in service across many different platforms. The liquid cooled ATR uses the same 'High Integrity Frame' construction as the other models in the range, but new side plates fitted to both sides provide redundancy, a reduced physical footprint and increased thermal capacity compared with the air-cooled version. The side plate assembly consists of precision machined side walls, fluid carrying pipes configured to avoid sharp bends, thermally conductive inserts and clamping brackets that can quickly be replaced as a complete sub-assembly in the field.

## FEATURES AND BENEFITS

- Conduction cooled ATR for VME, CPCI, VITA 41 (VXS), VITA 46 (VPX) and custom
- In accordance with ARINC 404/600
- Can accommodate up to 10 x 6U x 160mm conduction cooled cards
- In excess of 1KW input power
- Input Power MIL-STD-704E / DEF STAN 61-5
- DC 28V / 270V
- 1 and 3 phase 115VAC 400Hz on request
- Custom I/O options including MIL-STD wiring and connectors
- Interchangeable liquid cooled sidewalls
- Zero loss cooling connectors
- Choice of cooling fluids including Glycol, Kerosene, PAO, Salt Water, De-ionised water

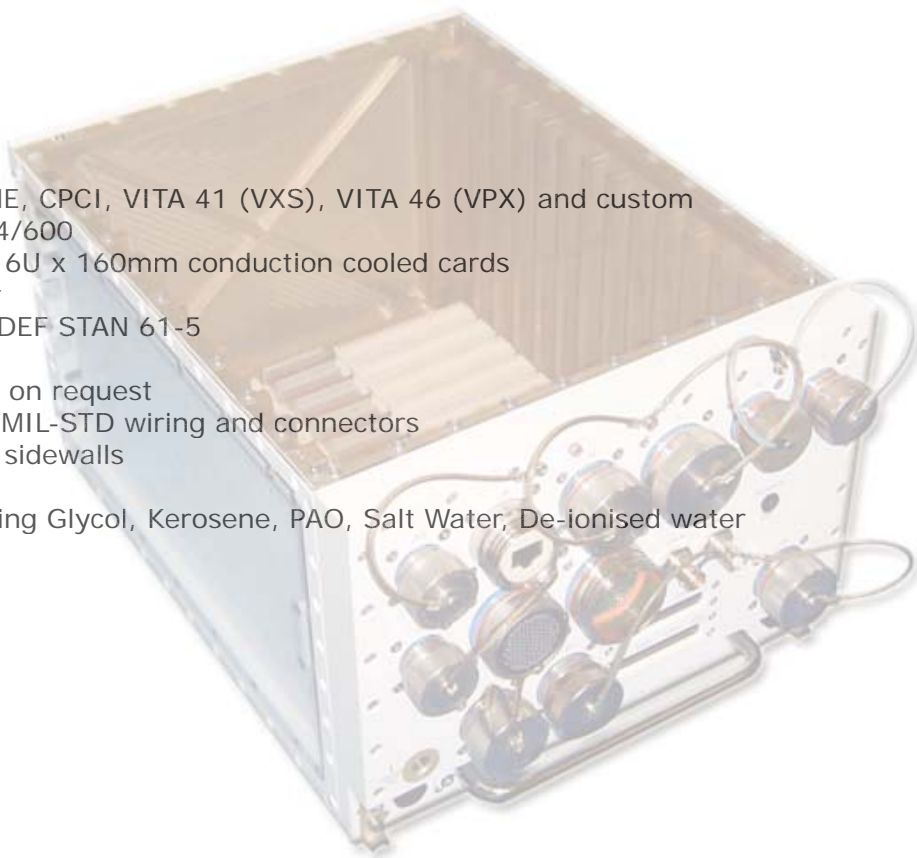

## ENTRY LEVEL DEVELOPMENT ATR

*For safe and reliable deployment of electronic hardware in moisture free air conditions*

The new Standard ATR is an affordable entry level convection cooled ATR comprising standard parts and fixings that can be used on many different size and format ATR enclosures. The enclosure can be taken at its base level and you need only migrate to a fully customised unit for final product definition, that is if you ever have to!

### FEATURES AND BENEFITS



- Design optimised to use common standard parts to reduce lead time and costs
- Split front panel, 2 standard front panel configurations: one for military circular connectors and one for various 'D Type' connectors
- I/O area is a separate and easily modified plate which can be removed without disturbing the top section
- Rear ARINC fixings made from steel for extra strength and durability
- Low cost sheet metal skeletal frame which can be assembled using only 2 different parts. The major benefit of this approach is that it allows many of the other enclosure assembly processes to be undertaken outside the frame and be fitted once built and tested.
- Card cage, available in 3U or 6U, can be moved up and down inside the enclosure, depending on daughter card front panel requirements.
- Small, high performance PAPST fans located closely on the card cage extrusions for "targeted airflow" allowing over 400LFM per slot with a noise level of less than 65dB.
- Captive 1/4 turn low profile screws are used on lid and base.



## Standard and Custom PSUs



- “Off the shelf” configured PSUs or full custom solutions
- Voltage rails tailored to application
- Custom solutions in accordance with Mil-Stds and Def-Stans

## Thermal Management

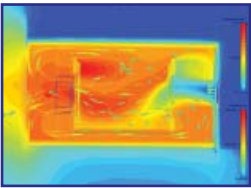

- Analysis tools used to maximise efficiency of thermal solution
- Test rigs developed to prove theory
- Expertise in convection, conduction and liquid cooling

## COTS and Custom Backplanes



- “Off the shelf” VME, VME64x, VXS, VPX, CPCI and  $\mu$ TCA backplanes
- Unrivalled experience in full custom Mil-Spec backplanes
- Design verification tools in 2 global locations

## I/O Solutions



- Mil-grade wiring solutions
- Custom break-out boards and flexi-circuit solutions
- Design tools used to optimise I/O solutions

## Environmental Expertise



- Expertise in shock, vibration, EMC and climate testing
- In house pre-compliance EMC chamber
- Latest design and verification tools

## Project Management

- From inception through to deployment
- Years of experience with numerous deployed military applications
- Q.A. Systems tailored to demanding applications

## TYPICAL SPECIFICATIONS FOR ELMA ATR ENCLOSURES

### *Convection Cooled ATR Enclosures*

PROPERTIES	APPROPRIATE STANDARDS
OPERATING TEMPERATURE STORAGE TEMPERATURE	MIL-STD-810
EMC	MIL-STD-461 DEF.STAN 59-41 BS3G100 TEMPEST DEF STAN 59-41
POWER INPUTS	MIL-STD-704A and 704F MIL-STD-1275 DEF.STAN 61-5 (Naval) MIL-STD-1399 (Naval) EN50155 / RIA12 (Railway)
WIRING	MIL-C-24643 DEF.STAN 61-12 Part 18 DEF.STAN 66-31
MECHANICAL	ARINC 404A, ARINC 600
IP RATING	DIRECT COOLING UP TO IP62 INDIRECT COOLING UP TO IP66
VIBRATION	MIL-STD-810 Method 514.5 MIL-STD-167 DEF.STAN 66-31 DEF.STAN 00-35
SHOCK	MIL-STD-810 Method 516.4 Proc I - VI
ACCELERATION	MIL-STD-810 Method 513.5
ALTITUDE	MIL-STD-810 Method 500.4
HUMIDITY	MIL-STD-810F Method 507.4
SALT FOG*	MIL-STD-810 Method 509.4
FUNGAL GROWTH*	MIL-STD-810 Method 508.5
THERMAL SHOCK*	MIL-STD-810 Method 503.4
SAND & DUST*	MIL-STD-810 Method 510.4
EPOXY PAINT FINISH	MIL-C-22750 DTD-5555A MIL-STD-810 Method 504-1

\*Indirect convection cooling only

# STANDARD ATR DIMENSIONS

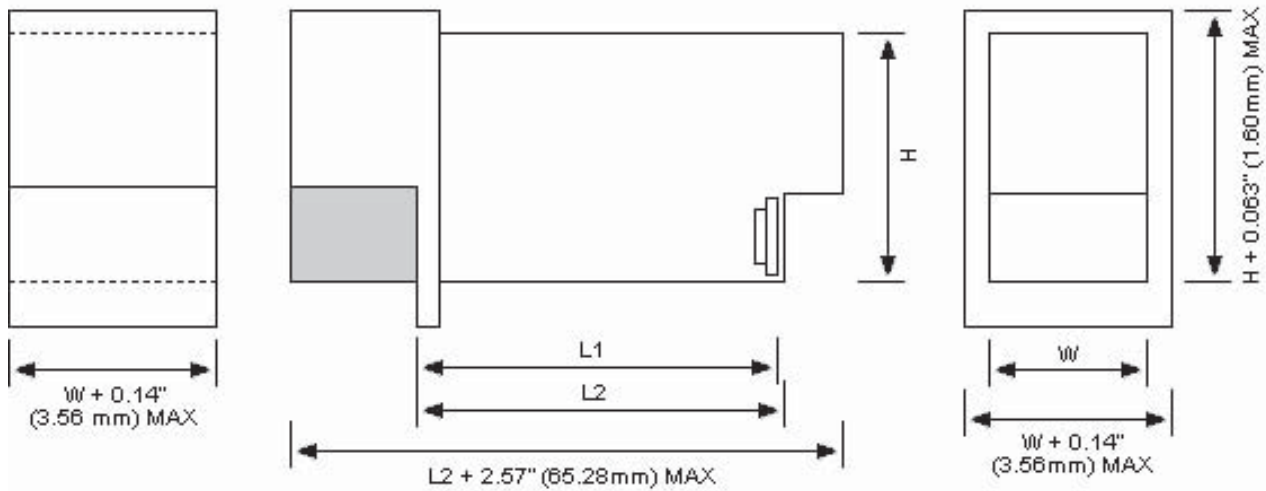

ARINC SPECIFICATION 404A										VME BOARD CAPACITY				
ATR SIZE	APPROX VOLUME		WIDTH (W)		LENGTH (L)		LENGTH (L2) MAX		HEIGHT (H) MAX		CONVECTION COOLED		CONDUCTION COOLED	
											HORIZONTAL (SIDE) BOARD LOAD MAX NO. SLOTS	VERTICAL (TOP) BOARD LOAD MAX NO. SLOTS	HORIZONTAL (SIDE) BOARD LOAD MAX NO. SLOTS	VERTICAL (TOP) BOARD LOAD MAX NO. SLOTS
	in <sup>2</sup>	litre	±.03in	±.76mm	±.04in	± 1.0mm	in	mm	in	mm				
1/4 short	215	3.52	2.25	57.15	12.52	318.0	12.62	320.5	7.62	193.5	N/A	1 slot	N/A	1 slot
1/4 long	335	5.49	2.25	57.15	19.52	495.8	19.62	498.3	7.62	193.5	N/A	1 slot	N/A	1 slot
1/2 short	470	7.70	4.88	123.95	12.52	318.0	12.62	320.5	7.62	193.5	N/A	5 slots	N/A	5 slots
1/2 long	725	11.88	4.88	123.95	19.52	495.8	19.62	498.3	7.62	193.5	N/A	5 slots	N/A	5 slots
3/4 short	720	11.80	7.50	190.50	12.52	318.0	12.62	320.5	7.62	193.5	N/A	8 slots	N/A	8 slots
3/4 long	1120	18.36	7.50	190.50	19.52	495.8	19.52	493.8	7.62	193.5	N/A	8 slots	N/A	8 slots
1 short	975	15.98	10.12	257.05	12.52	318.0	12.62	320.5	7.62	193.5	8 slots	12 slots	8 slots *	10 slots
1 long	1510	24.75	10.12	257.05	19.52	495.8	19.62	498.3	7.62	193.5	8 slots	12 slots	8 slots *	15 slots
1 1/2	2295	37.62	15.38	390.65	19.52	495.8	19.62	498.3	7.62	193.5	8 slots	18 slots	8 slots *	N/A

Notes:

- Requires "Tall Box" height dimension up to 269.88mm (10.625in)
- Where the maximum 'H' dimension shown is insufficient for equipment reasons, it is suggested that the 'Tall Box' maximum 'H' dimension of 269.88mm (10.625in) be adhered to as specified in ARINC characteristic 561 INS

\* When utilising 'Tall Box' maximum = 13 slots

## STANDARD ATR DIMENSIONS

### *Mechanical Fragility Factors for Typical COTS System Components*

COMPONENT	VIBRATING OPERATING	VIBRATING NON-OPERATING	SHOCK OPERATING	SHOCK NON-OPERATING
VME Backplane	5g - 20g rms	5g - 20g rms	100g 6 ms	100g 6 ms
	10Hz - 2000Hz	10Hz - 2000Hz		
Convection Cooled VME Daughter Boards	2g Sinusoidal	2g Sinusoidal	12g - 20g Peak Sawtooth, 11ms	12g - 20g Peak Sawtooth, 11ms
	5Hz - 500Hz	5Hz - 500Hz		
	0.002g <sup>2</sup> / Hz (Random)	0.002g <sup>2</sup> / Hz (Random)		
	10Hz - 2000Hz	10Hz - 2000Hz		
Conduction Cooled VME Daughter Boards - Military Grade	0.1g <sup>2</sup> / Hz	0.1g <sup>2</sup> / Hz	40g Sawtooth, 11ms	40g Sawtooth, 11ms
	5Hz - 2000Hz	5Hz - 2000Hz		
Hard Disk Drive	0.1g, 5Hz-32Hz	0.1g, 5Hz - 28Hz	5g	75g
	0.5g, 32Hz - 400Hz	4g, 28Hz - 400Hz		
Floppy Disk Drive	0.5g, 5Hz - 55Hz	5g, 5Hz - 55Hz	0.5g	40g
CD ROM	0.3g, 5Hz - 300Hz	2g, 7Hz - 300Hz	10g	50g
Open Frame Power Supply	0.15mm Peak	0.15mm Peak	> 10g 10 ms	> 10g 10 ms
	10Hz - 55Hz	10Hz - 55Hz		
	2g, 55Hz - 500Hz	2g, 55Hz - 500Hz		

## TYPICAL SPECIFICATIONS FOR ELMA ATR ENCLOSURES

### *Conduction Cooled ATR Enclosures*

PROPERTIES	APPROPRIATE STANDARDS
OPERATING TEMPERATURE	MIL-STD-810 Method 501.4, 502.4
STORAGE TEMPERATURE	Method 501.4, 502.4
EMC	MIL-STD-461 DEF.STAN 59-41 BS3G100 TEMPEST DEF.STAN 9-411
POWER INPUTS	MIL-STD-704A AND -704F MIL-STD-1275 DEF.STAN 61-5 (Naval) MIL-STD-1399 (Naval) EN50155 / RIA12 (Railway)
WIRING	MIL-C-24643 DEF.STAN 61-12 Part 15/1 DEF.STAN 66-31
MECHANICAL	ARINC 404A, ARINC 600 Complies with IEEE 1101.2
IP RATING	MIL-STD-810 Method 512.4 IP66/IP68
VIBRATION	MIL-STD-810 Method 514.5 MIL-STD-167 DEF.STAN 00-35 DEF.STAN 66-31
SHOCK	MIL-STD-810 Method 513.4
ACCELERATION	MIL-STD-810 Method 513.5
ALTITUDE	MIL-STD-810 Method 500.4
HUMIDITY	MIL-STD-810 Method 507.4
SALT FOG	MIL-STD-810 Method 509.4
FUNGAL GROWTH	MIL-STD-810 Method 508.5
THERMAL SHOCK	MIL-STD-810 Method 503.4
EPOXY PAINT FINISH	MIL-C-22750F DTD-5555A Method 504-1
SAND & DUST	MIL-STD-810 Method 510.4







**ELMA Electronic AG**  
Hofstrasse 93, Postfach  
CH-8620 Wetzikon  
Telephone +41 44 933 41 11  
Fax +41 44 933 42 15  
sales@elma.ch



**ELMA Electronic  
France SASU**  
ZA du Buisson Rond  
F-38460 Villemairieu  
Telephone +33 4 37 06 21 10  
Fax +33 4 37 06 21 19  
sales@elma-electronic.fr



**ELMA Electronic Inc.**  
44350 Grimmer Blvd.  
Fremont, CA 94538  
Telephone +1 510 656 3400  
Fax +1 510 656 3783  
sales@elma.com

**ELMA Bustronic Corp.**  
44350 Grimmer Blvd.  
Fremont, CA 94538  
Telephone +1 510 490 7388  
Fax +1 510 490 1853  
sales@elmabustronic.com

**ELMA Electronic/Optima EPS**  
2166 Mountain Industrial Blvd.  
Tucker, GA 30084  
Telephone +1 770 496-4000  
Fax +1 770 496-4041  
sales@elma.com



**ELMA Trenuew  
Electronic GmbH**  
Stuttgarter Strasse 11  
D-75179 Pforzheim  
Telephone +49 7231 97 340  
Fax +49 7231 97 34 97  
info@elma.de



**ELMA Electronic  
Israel Ltd.**  
34, Modi'in St.  
Sgula I.Z., Petach-Tikva, 49271 IL  
Telephone +972 3 930 5025  
Fax +972 3 931 3134  
sales@elma.co.il



**ELMA Electronic  
(China) Co., Ltd.**  
8F, 355, Fu Te Road (West 1)  
Wai Gao Qiao Free Trade Zone  
Pudong District  
Shanghai, 200131, China  
Telephone +86 21 5866 5908  
Fax +86 21 5866 5918  
sales@elmachina.com



**ELMA Electronic UK Limited**  
Solutions House  
Fraser Road, Priory Business Park  
Bedford, MK44 3BF  
Telephone +44 1234 838 822  
Fax +44 1234 836 650  
sales@elma-mektron.co.uk



**ELMA Electronic  
Romania SRL**  
Str. Maltopol Nr. 16  
011048 Bucharest  
Telephone +40 213 107 998  
Fax +40 213 107 992

Calea Buziasului Nr. 11  
A300699 Timisoara  
Telephone +40 256 222 290  
Fax +40 256 222 490  
info@elma.ro

Your local partner :

**Altis Technology**

Fort Lauderdale

david@altistechnology.com

954-522-9300