

XCalibur1501

Freescale MPC8572E PowerQUICC™ III 6U Conduction- or Air-Cooled CPCI Module

- › Freescale MPC 8572E PowerQUICC™ III processor with dual PowerPC e500 cores at up to 1.5 GHz
- › Conduction or air cooling
- › Two Channels of up to 4 GB (2 GB each) DDR2-800 ECC SDRAM
- › Up to 256 MB of NOR Flash (with redundancy)
- › Up to 4 GB of NAND Flash
- › Four Gigabit Ethernet Ports
- › x8 PCI Express to XMC sites
- › Two SATA 3.0 ports to J5
- › Three USB 2.0 ports (one configurable to front panel and two to J5)
- › Two RS-232/RS-422/RS-485 serial ports
- › Two PrPMC/XMC Interfaces
- › Linux LSP
- › Wind River VxWorks BSP
- › QNX Neutrino BSP
- › Green Hills INTEGRITY BSP

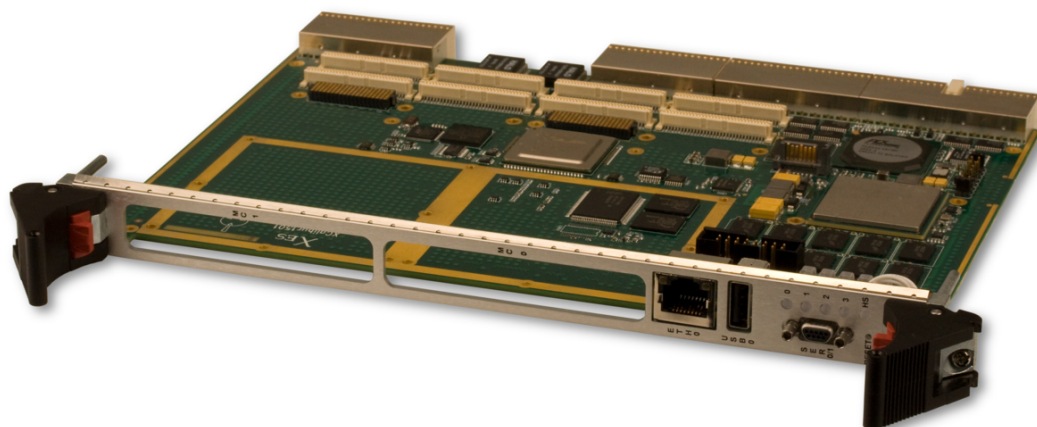

XCalibur1501

The XCalibur1501 is a high-performance 6U Compact PCI single-board multiprocessing computer that is ideal for ruggedized systems requiring high bandwidth processing and low power consumption. With dual PowerPC e500 cores running at up to 1.5 GHz, the MPC8572E delivers enhanced performance and efficiency for today's embedded computing applications.

The XCalibur1501 provides two separate channels of up to 4 GB (2 GB each) DDR2-800 ECC SDRAM, two PrPMC/XMC slots, as well as 256 MB of NOR flash (with redundancy). The XCalibur1501 also supports four Gigabit Ethernet ports, I²C, PMC I/O, XMC I/O, and RS-232/422/485 serial ports out the front panel or J5 connector.

The XCalibur1501 is a powerful, feature-rich solution for the next generation of computationally intensive embedded applications. Operating system support for VxWorks, INTEGRITY, QNX and Linux are available.

X-ES

Extreme Engineering Solutions

...Always Fast

Extreme Engineering Solutions

3225 Deming Way, Suite 120 • Middleton, WI 53562
 Phone: 608.833.1155 • Fax: 608.827.6171
 sales@xes-inc.com • <http://www.xes-inc.com>

Processing Nodes

- Freescale MPC 8572E PowerQUICC III processor
- Dual PowerPC e500 cores at up to 1.5 GHz
- 1 MB of shared L2 cache

Memory

- Two channels of DDR2 ECC SDRAM, up to 4 GB (2 GB each)
- Up to 4 GB of NAND flash
- Up to 256 MB of NOR flash (with redundancy)
- 16 KB I²C EEPROM
- Trusted Platform Module (optional)

CPCI

- 66 MHz 64-bit PCI interface to J1 and J2
- PICMG 2.1 (Hot swap support)
- PICMG 2.3 (PMC I/O to J3 and J5)
- PICMG 2.9 (Dedicated IPMI Controller)
- PICMG 2.16 (Two 10/100/1000 Base-T Ethernet ports)

Front Panel

- Dual RS-232 serial ports
- One or two Gigabit Ethernet ports
- USB 2.0
- General purpose LEDs

Back Panel

- Dual RS-232/RS-485 serial ports
- Two Gigabit Ethernet ports
- Dual SATA ports
- PMC I/O
- Dual USB 2.0 ports

Software Support

- Linux LSP
- Wind River VxWorks BSP
- QNX Neutrino BSP
- Greens Hills INTEGRITY BSP

Environmental Requirements

Contact factory for appropriate board configuration based on environmental requirements.

- Supported ruggedization levels (see chart below):
Level 1, Level 2, Level 3, Level 4, Level 5
- Humidity: 0% to 95% non-condensing

Power Requirements

Tested with MPC8572E at 105 °C

- 36 W (est.) per board

Ruggedization Level	Level 1	Level 2	Level 3	Level 4	Level 5
Cooling Method	Standard Air-Cooled	Extended Air-Cooled	Rugged Air-Cooled	Conduction-Cooled	Conduction-Cooled
Operating Temperature	0 to +55 °C	0 to +65 °C	-40 to +70 °C	-40 to +70 °C	-40 to +85 °C
Vibration	0.002 g ² /Hz	0.002 g ² /Hz	0.04 g ² /Hz	0.1 g ² /Hz	0.1 g ² /Hz
Shock	20 g	20 g	40 g	40 g	40 g
Storage Temperature	-40 to +105 °C	-40 to +105 °C	-55 to +105 °C	-55 to +105 °C	-55 to +105 °C

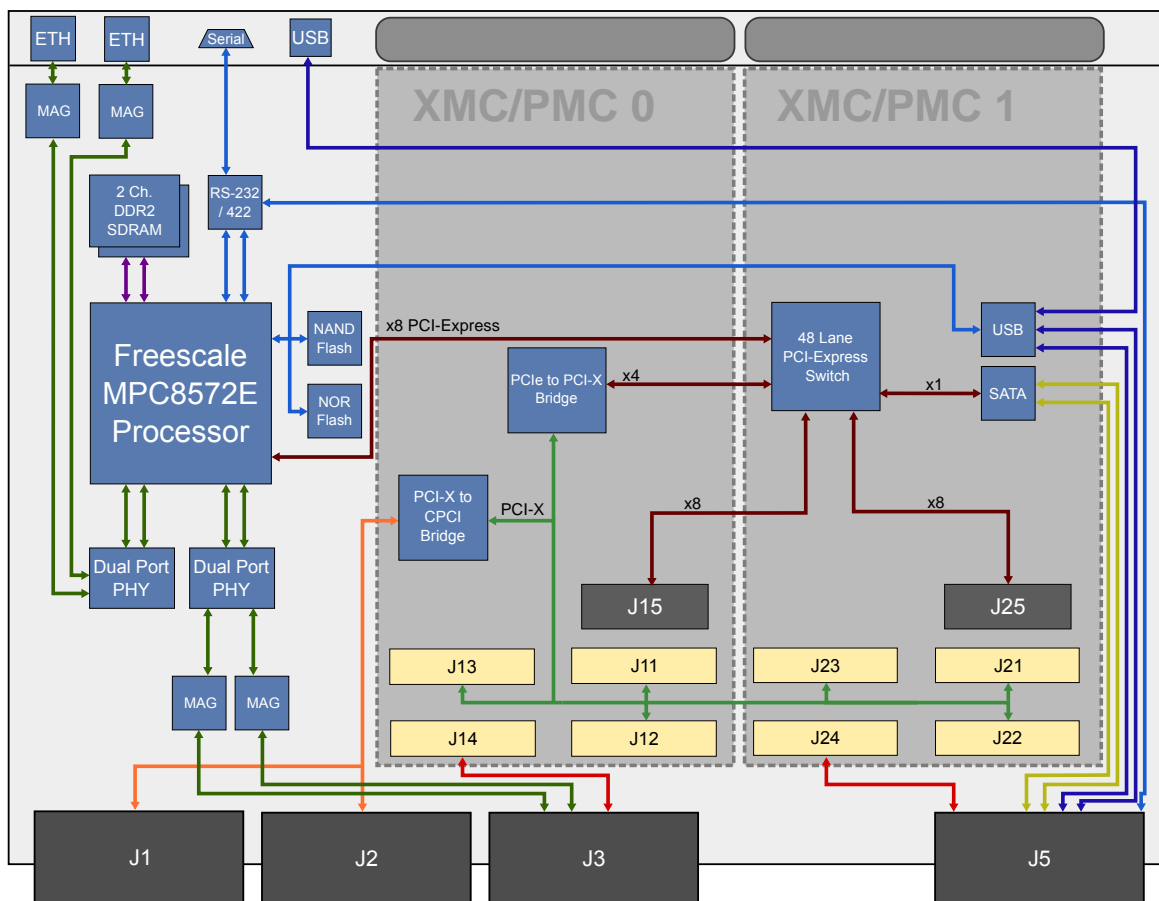

XCalibur1501



ISO 9001:2000
FM 87995